



# Williams Products, Inc

1750 Mapelawn  
Troy, MI. 48084  
Toll Free: 800-521-9594 Phone: 248-643-6400  
Fax: 248-643-7117

## The Problem:

An accumulation of ice or ponding of water on a staircase or noisy stairwells in residential or commercial areas

## The Solution:

An "All Weather" covering made of natural rubber designed to break ice build up on stairways with each step, to channel water from under foot, improving safety and reducing the use of products or equipment that may cause damage to the stair material. Current solutions are not the answer.

Shovels and chisel/scrapers damage the steps. Salt is ineffective at -15°F and carpets of jute or synthetic turf absorb water and freeze, creating hazardous conditions.

# FLEX-STEP

## The "All Weather" Stair Covering

Designed for durability

Breaks Ice and Channels Water  
Offers Sure Grip with Every Step



## Advantages:

- ❖ Flexible in cold weather
- ❖ Placing foot's weight on step causes cover to sink breaking ice
- ❖ No effort needed to break ice
- ❖ Channels water from under foot
- ❖ Sure grip grooves reduce risk of falling
- ❖ Noise/Vibration dampening on staircases of all types
- ❖ Does not absorb water
- ❖ Easy to maintain, cleans with a broom and mild soap
- ❖ No need for harsh abrasives or chemicals
- ❖ Permanent installation
- ❖ Resistant to ice melting products (salt, potassium/calcium chloride)
- ❖ Less accumulation of ice

## Easy to Install:

- ❖ Center Flex-Step on each step.
- ❖ Install the front screws in the pre-drilled first starting at the center and going outward.
- ❖ Push the Flex-Step toward the back and install rear screws in the pre-drilled holes flush to the tread without pressure.

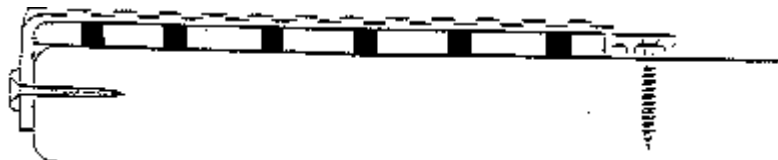
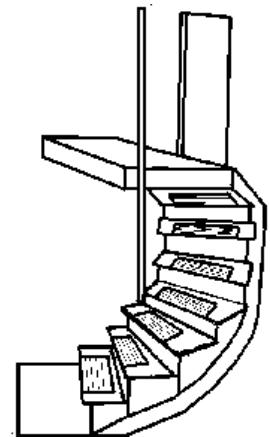
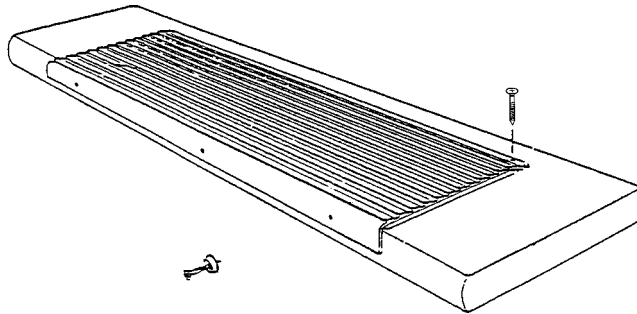

\*Flex-Step must be properly anchored to stair tread for proper operation and safety. (Anchors not included)

\*\*Flex-Step is available in 26" lengths or may be joined together for custom lengths or factory cut to specified lengths

We do not guarantee the applicability or accuracy of this information or the suitability of our products for any given situation. The products discussed are sold without warranty, expressed or implied. Buyer assumes all responsibility for any loss or damage arising from the handling or use of our products, whether done in accordance with directions or not. Statements concerning the possible use of our products are not intended as recommendations to use our products in the infringement of any patent.

Flex-Step © 2003 Williams Products Inc. Visit Williams Products Inc. on the web at [www.williamsproducts.net](http://www.williamsproducts.net)